

## TECHNICAL DATA

### Measurements

Width, head open	1 670 mm
Width, head closed	1 220 mm
Weight (from)	1 540 kg
Height (in processing position)	1 890 mm
Length (in processing position)	1 585 mm
Optimal tree diameter	500 mm

### Delimiting

Number of delimiting knives	4+1
Max opening of front knives	720 mm
Max opening of rear knives	750 mm
Diameter front knives tip-to-tip	480 mm

### Feeding

Type of feed	3WD
Diameter of feed rollers	450 mm
Max opening of feed rollers	680 mm

### Hydraulics

Recommended pressure min	250 bar
Max pressure	280 bar
Recommend oil flow min	250 l/min
Max oil flow	300 l/min

### Electronics

Voltage	24 V
Current	15 A

### Recommended base machine

Excavator min weight	16 t
Excavator max weight	20 t
Wheeled harvester min weight	20 t
Wheeled harvester max weight	25 t

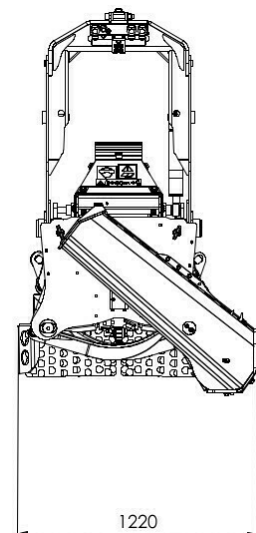
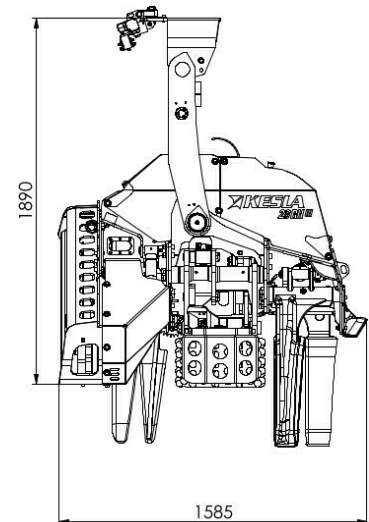
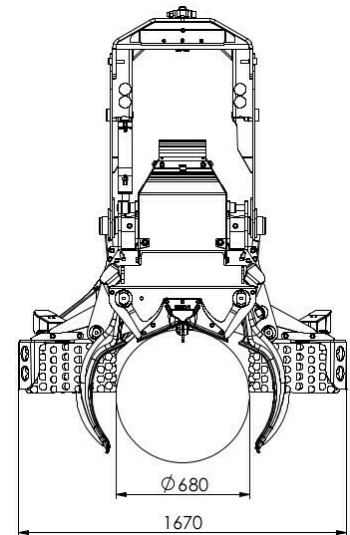

## SAW AND FEEDMOTOR CONFIGURATION

### Chain Saw Options

#### JPS R5500 41cc saw with auto chain tensioner & auto saw control

Max cutting diameter	770 mm
Max guide bar length	90 cm
Chain pitch	0.404 "
Saw motor displacement	41 cc
Chain tightener	auto
Saw control	auto



#### KESLA HD30 with automatic chain tensioner & auto saw control

Max cutting diameter	770 mm
Max guide bar length	90 cm
Chain pitch	0.404 "
Saw motor displacement	30 cc
Chain tightener	auto
Saw control	auto

#### KESLA HD30 3/4" with auto chain tensioner & auto saw control

Max cutting diameter	770 mm
Max guide bar length	90 cm
Chain pitch	0.75 "
Saw motor displacement	30 cc
Chain tightener	auto
Saw control	auto

#### SuperCut 150 saw with automatic chain tensioner and saw control

Max cutting diameter	770 mm
Max guide bar length	90 cm
Chain pitch	0.404 "
Saw motor displacement	30 cc
Chain tightener	auto
Saw control	auto

### Feed Motor Options

#### Rexroth 680cc

Feed motor displacement	680 cc
Feed force	26.9 kN
Feed speed	5 m/s
Recommended flow	290 l/min
Recommended engine power min	130 kW

## OPTIONAL EQUIPMENT

### Control valve

HA01-030-10	STD (mechanical clamping pressure control)
HA01-030-11	KESLA proCON

### Saw bar pressure control

HA01-050-10	STD (Manual)
HA01-050-11	Proportional

### Tilt control

HA01-055-10	STD tilt
HA01-055-11	proTILT
HA01-055-12	proTILT Lock

### Chain oil pump

HA01-060-10	Fixed volume, hydraulic
HA01-060-11	KESLA Prolube, electric adjustable
HA01-060-12	PROLUBE DUAL

### Feed roller

HA01-070-10	STD (KESLA steel rollers)
HA01-070-55	MOIPU Xtreme

### Middle roller

HA01-080-10	STD
-------------	-----

### Length measuring

HA01-090-12	measuring roller KESLA HydCON+
HA01-090-13	KESLA hydCON+ w/ wide sprocket
HA01-090-14	Sensors in feed motors

### Diameter measuring

HA01-100-10	No diameter measuring equipment installed
HA01-100-11	STD Analog sensor, current output (mA)
HA01-100-12	Double pulse encoders

### Wire harness for control system

HA01-110-10	None
HA01-110-11	Motomit
HA01-110-12	KESLA proLOG or xLogger
HA01-110-13	Dasa d4

### Front delimiting knives

HA01-115-10	STD cast knives
HA01-115-11	HD knives (cast)

### Pressure accumulators for knives

HA01-120-13	Front & rear knives
HA01-120-14	Front & rear knives (accumulators unpressurized for air freight)

**Upper fixed delimiting knife**

HA01-130-10	STD (casted knife)
HA01-130-11	SHORT (27RH-II... 30RH-II, welded steel)

**Color marking** HA01-170-11

**Stump treatment** HA01-180-11

**Control valve for rotator** HA01-190-11

**Find end sensor** HA01-210-11

**Spare hose kit** HA01-220-11

**Spare parts kit**

HA01-230-11	STD kit (for a head with measuring wheel)
HA01-230-12	For head with length encoders in feed motors

**Tool kit**

HA01-240-11	KESLA special tool kit
HA01-240-12	Universal tool kit
HA01-240-13	KESLA special tool kit + Universal tool kit

**Rotator & link**

HA01-250-11	Black Bruin BBR15HD + link 250 mm w/ dual swing damper (#3160256)
HA01-250-13	Indexator AV 17 (#3160469) + link w/o swing damper (#90019958)
HA01-250-50	Black Bruin RH3016 + 240 mm link w/ dual swing damper
HA01-250-51	Black Bruin RH3016 + 240 mm link w/o swing damper
HA01-250-60	Indexator HX30LS + MPB-link w/ double swing dampers

**Control and Measuring System**

HA01-260-11	KESLA xLogger with Priority-Bucking software
HA01-260-12	KESLA proLOG
HA01-260-14	KESLA xLogger with Bucking-to-value software

**Installation kit for control and measuring system**

HA01-270-11

**Joystick grips**

HA01-280-11	SUREGRIP with 2x10 buttons preset keypads
HA01-280-12	SUREGRIP with 1x10 buttons preset keypad
HA01-280-15	SVAB grips